

SoftPLC Web Studio - HMI Models SSH-3Cx

(Where "x" is the runtime license size)

Standard models are equipped with WindowsCE, a 512MB Compact Flash, and a softkey license. Alternative storage media size, license types or other options are available. Contact SoftPLC for a quote to match your specific requirements.

SPECIFICATIONS				
SYSTEM HARDWARE		LCD DISPLAY		
CPU	Cortex-A8 600MHz	Display Size / Type	3.5" QVGA TFT LCD	
Ports	LAN	10/100Base-T x 1	Max Resolution	320 x 240
	Serial	RS-232/RS-485 X1	Max Colors	64K
	USB	USB 2.0(Host) x1	Luminance cd/m²	450
Storage	512MB on board micro SD card 1Mbit FRAM for Data back-up (optional)	Viewing Angle (H/V)	160/140	
		Backlight Life	30,000 hours	
Memory	256MB DDR2 on board	Contrast Ratio	300:1	
Watchdog Timer	Programmable-250ms/500ms/1sec	ENVIRONMENT		
TOUCHSCREEN		Humidity	10 ~ 95% @ 40°C	
Lifespan (min)	1M activations	Protection	Ingress	Front Panel: NEMA4, IP65
Light Transmission	Above 80%		Vibration	2 Grms (Operating, Random)
Resolution / Type	Linearity / 4-wire, analog resistive	Temperature	Operating	0 ~ 50°C, 32 ~ 122°F
			Storage	-20 ~ 60°C, -4 ~ 140°F
		Certifications	BSMI, CE, FCC Class A, UL	
MECHANICAL				
Enclosure	ABS	Power	Consumption	8W
Weight (Net)	0.25 kg, 0.55 lbs		Input	18 ~ 28VDC
Cooling System	Fanless Design	Recommended Power Supply		ICO-PS4024
Dimensions (WxHxD)	4.76 x 3.37 x 1.04 in 120.8 x 85.5 x 26.5 mm	Panel Cut-Out Dimensions		4.6 x 3.18 in 115 x 79.5 mm

Dimensions

Units=mm

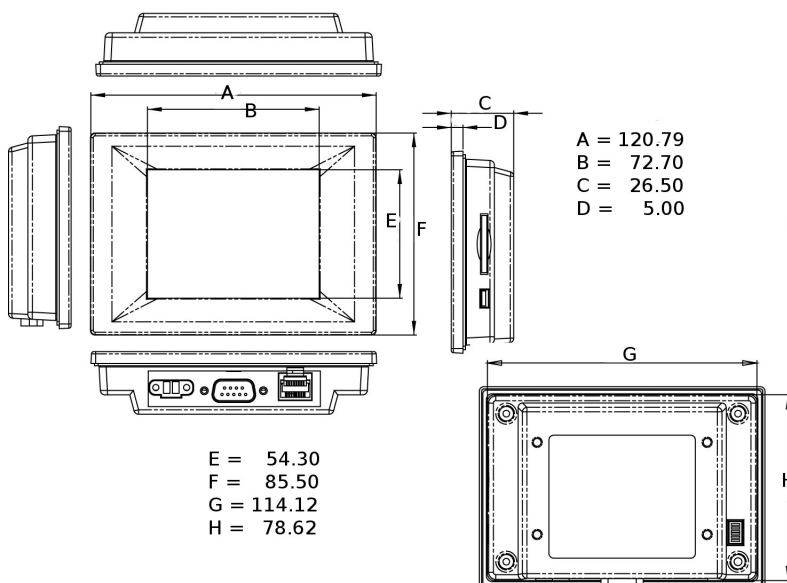

Rear View

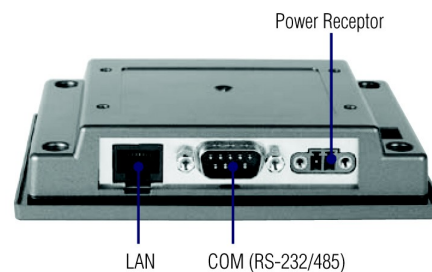

Side View

